

LM1815 Adaptive Variable Reluctance Sensor Amplifier

General Description

The LM1815 is an adaptive sense amplifier and default gating circuit for motor control applications. The sense amplifier provides a one-shot pulse output whose leading edge coincides with the negative-going zero crossing of a ground referenced input signal such as from a variable reluctance magnetic pick-up coil.

In normal operation, this timing reference signal is processed (delayed) externally and returned to the LM1815. A logic input is then able to select either the timing reference or the processed signal for transmission to the output driver stage.

The adaptive sense amplifier operates with a positive-going threshold which is derived by peak detecting the incoming signal and dividing this down. Thus the input hysteresis varies with input signal amplitude. This enables the circuit to sense in situations where the high speed noise is greater than the low speed signal amplitude. Minimum input signal is 100 mVp-p.

Features

- Adaptive hysteresis
- Single supply operation
- Ground referenced input
- True zero crossing timing reference
- Operates from 2V to 12V supply voltage
- Handles inputs from 100 mV to over 120V with external resistor
- CMOS compatible logic

Applications

- Position sensing with notched wheels
- Zero crossing switch
- Motor speed control
- Tachometer
- Engine testing

Connection Diagram

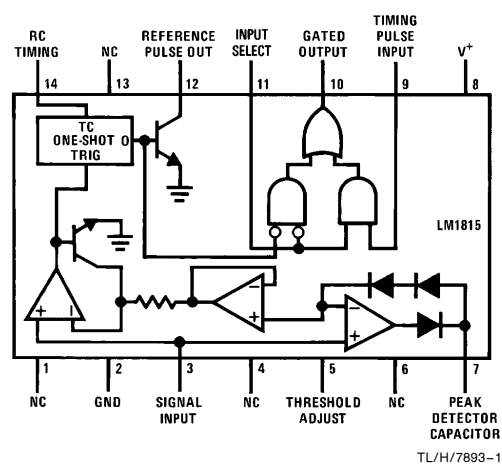

Truth Table

Signal Input	Input Select	Timing Input	Gated Output
Pulses	L	X	Pulses
X	H	Pulses	Pulses

Absolute Maximum Ratings

If Military/Aerospace specified devices are required, please contact the National Semiconductor Sales Office/Distributors for availability and specifications.

Supply Voltage	12V
Power Dissipation (Note 1)	1250 mW
Operating Temperature Range	-40°C to +125°C

Storage Temperature Range	-65°C to +150°C
Junction Temperature (Note 2)	+125°C
Input Current	±30 mA
Lead Temperature (Soldering, 10 sec.)	260°C

Electrical Characteristics (T_A = 25°C, V_{CC} = 10V, unless otherwise specified, see Figure 1)

Parameter	Conditions	Min	Typ	Max	Units
Operating Supply Voltage		2.5	10	12	V
Supply Current	f _{IN} = 500 Hz, Pin 9 = 2V, Pin 11 = 0.8V		3.6	6	mA
Reference Pulse Width	f _{IN} = 1 Hz to 2 kHz	70	100	130	μs
Input Bias Current	V _{IN} = 2V, (Pin 9 and Pin 11)			5	μA
Input Bias Current	V _{IN} = 0V dc, (Pin 3)		200		nA
Input Impedance	V _{IN} = 5 Vrms, (Note 3)	12	20	28	kΩ
Zero Crossing Threshold	V _{IN} = 100 mVp-p, (Pin 3)			25	mV
Logic Threshold	(Pin 9 and Pin 11)	0.8	1.1	2.0	V
V _{OUT} High	R _L = 1 kΩ, (Pin 10)	7.5	8.6		V
V _{OUT} Low	I _{SINK} = 0.1 mA, (Pin 10)		0.3	0.4	V
Input Arming Threshold	Pin 5 Open, V _{IN} ≤ 135 mVp-p	30	45	60	mV
	Pin 5 Open, V _{IN} ≥ 230 mVp-p	40	80	90	% of V ₃ Pk
	Pin 5 to V ⁺	200			mV
	Pin 5 to Gnd	-25		25	mV
Output Leakage Pin 12	V ₁₂ = 11V		0.01	10	μA
Saturation Voltage P12	I ₁₂ = 2 mA		0.2	0.4	V

Note 1: For operation at elevated temperatures, the device must be derated based on a 125°C maximum junction temperature and a thermal resistance of 80°C/W (DIP), 120°C/W (SO-14) junction to ambient.

Note 2: Temporary excursions to 150°C can be tolerated.

Note 3: Measured at input to external 18 kΩ resistor. IC contains 1 kΩ in series with a diode to attenuate the input signal.

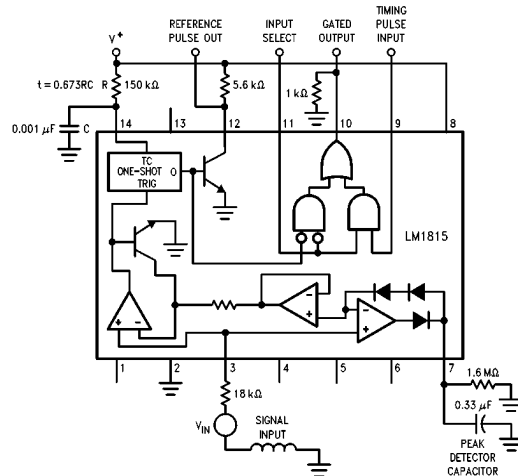
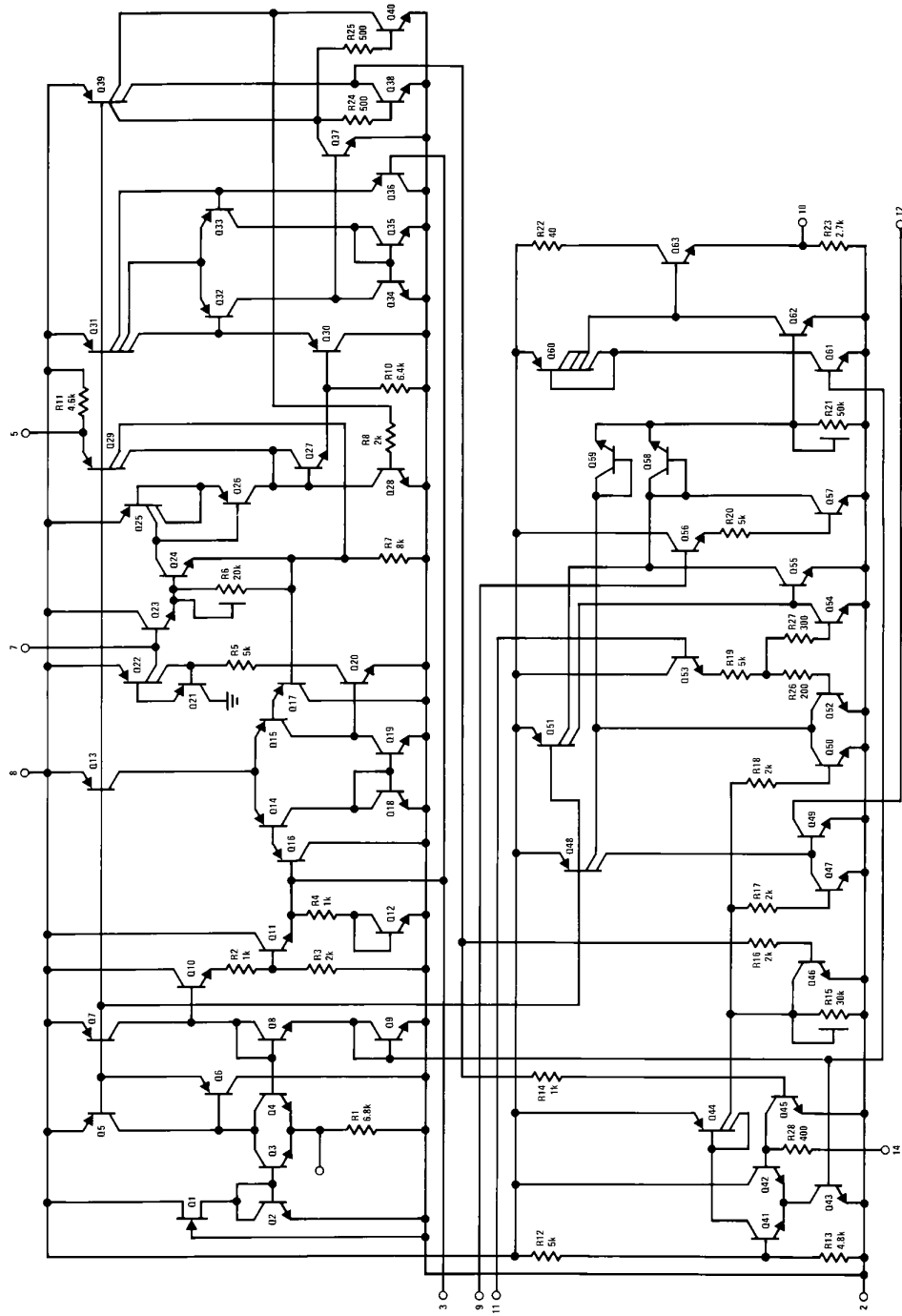

FIGURE 1. LM1815 Adaptive Sense Amplifier

TL/H/7893-2

Schematic Diagram



TL/H/7893-4

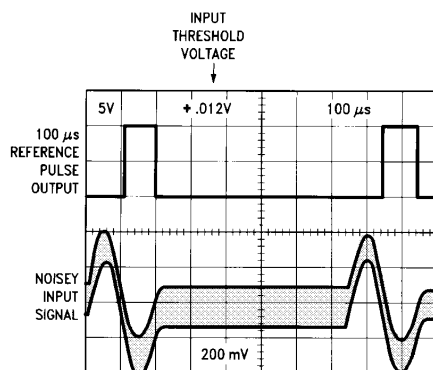

TL/H/7893-3

FIGURE 2. LM1815 Oscillograms

Application Hints

Input Clamp

The signal input at pin 3 is internally clamped. Current limit is provided by an external resistor which should be selected to allow a peak current of 3 mA in normal operation. Positive inputs are clamped by a 1 k Ω resistor and series diode, while an active clamp limits pin 3 to -350 mV for negative inputs (see R4, Q12, Q11 in internal schematic diagram).

Operation of Zero Crossing Detector

The LM1815 is designed to operate as a zero crossing detector, triggering an internal one shot on the negative-going edge of the input signal. Unlike other zero crossing detectors, the LM1815 cannot be triggered until the input signal has crossed an "arming" threshold on the positive-going portion of the waveform. The arming circuit is reset when the chip is triggered, and subsequent zero crossings are ignored until the arming threshold is exceeded again. This threshold varies depending on the connection at pin 5. Three different modes of operation are possible:

MODE 1, Pin 5 open. The adaptive mode is selected by leaving pin 5 open circuit. For input signals of less than 135 mVp-p, the input arming threshold is typically 45 mV. Under these conditions the input signal must first cross the 45 mV threshold in the positive direction to arm the zero crossing detector, and then cross zero in the negative direction to trigger it. If the signal is less than 30 mV peak (minimum rating in Electrical Characteristics), the one shot is guaranteed to not trigger.

Input signals of greater than 230 mVp-p cause the arming threshold to track at 80% of the peak input voltage. A peak detector (pin 7) stores a value relative to the positive input peaks to establish the arming threshold. Input signals must exceed this threshold in the positive direction to arm the zero crossing detector, which can then be triggered by a negative-going zero crossing. The peak detector tracks rap-

idly as the input signal amplitude increases, and decays by virtue of the resistor connected externally at pin 7 to track decreases in the input signal.

Note that since the input is clamped, the waveform observed at pin 3 is not identical to the waveform observed at the variable reluctance sensor. Similarly, the voltage stored at pin 7 is not identical to the peak voltage appearing at pin 3.

MODE 2, Pin 5 connected to V+. The input arming threshold is fixed at 200 mV minimum when pin 5 is connected to the positive supply. The chip has no output for signals of less than 200 mV peak, and triggers on the next negative-going zero crossing when the threshold is exceeded.

MODE 3, Pin 5 grounded. With pin 5 grounded, the input arming threshold is set to 0V (± 25 mV maximum). Positive-going zero crossings arm the chip, and the next negative zero crossing triggers it.

The one shot timing is set by a resistor and capacitor connected to pin 14. The output pulse width is

$$\text{pulse width} = 0.673 RC \quad (1)$$

In some systems it is necessary to externally generate pulses, such as during stall conditions when the variable reluctance sensor has no output. External pulse inputs at pin 9 are gated through to pin 10 when Input Select (pin 11) is pulled high. Pin 12 is a direct output for the one shot and is unaffected by the status of pin 11.

Input/output pins 9, 11, 10 and 12 are all CMOS logic compatible. In addition, pins 9, 11 and 12 are TTL compatible. Pin 10 is not guaranteed to drive a TTL load.

Pins 1, 4, 6 and 13 have no internal connections and can be grounded.

Physical Dimensions inches (millimeters)

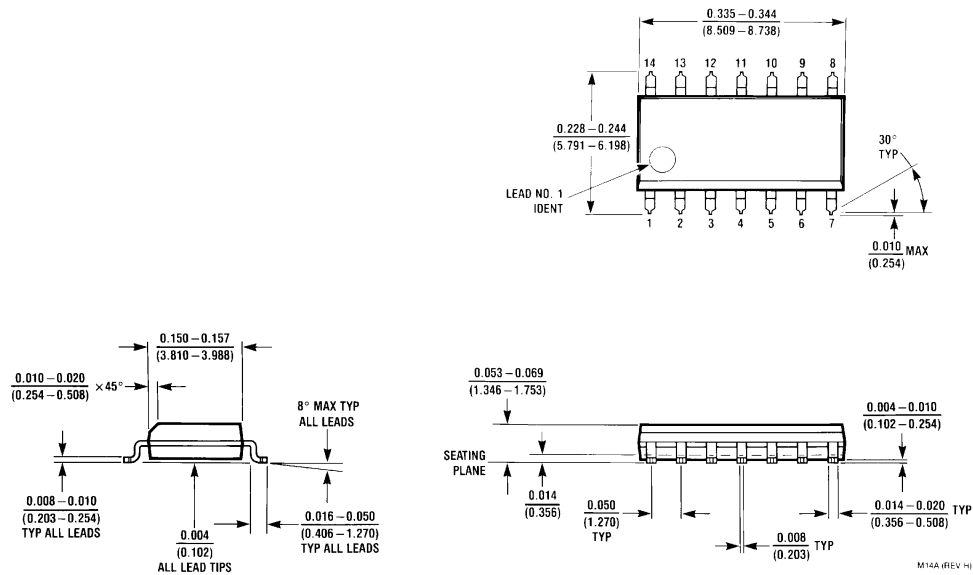

14-Lead Small Outline Integrated Circuit (M)
Order Number LM1815M
NS Package Number M14A

M14A (REV H)

Physical Dimensions inches (millimeters) (Continued)

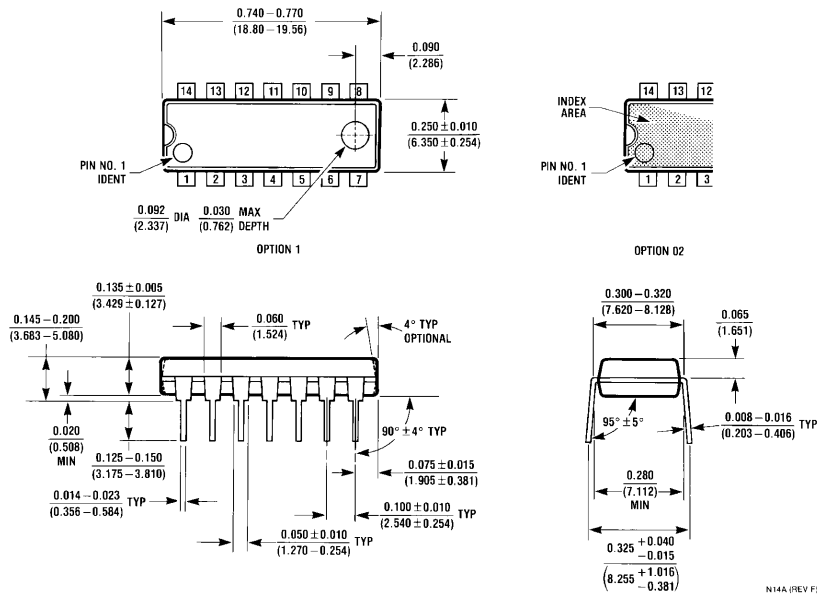

Molded Dual-In-Line Package (N)
Order Number LM1815N
NS Package Number N14A

N14A (REV F)

LIFE SUPPORT POLICY

NATIONAL'S PRODUCTS ARE NOT AUTHORIZED FOR USE AS CRITICAL COMPONENTS IN LIFE SUPPORT DEVICES OR SYSTEMS WITHOUT THE EXPRESS WRITTEN APPROVAL OF THE PRESIDENT OF NATIONAL SEMICONDUCTOR CORPORATION. As used herein:

1. Life support devices or systems are devices or systems which, (a) are intended for surgical implant into the body, or (b) support or sustain life, and whose failure to perform, when properly used in accordance with instructions for use provided in the labeling, can be reasonably expected to result in a significant injury to the user.
2. A critical component is any component of a life support device or system whose failure to perform can be reasonably expected to cause the failure of the life support device or system, or to affect its safety or effectiveness.



National Semiconductor Corporation
 1111 West Bardin Road
 Arlington, TX 76017
 Tel: 1(800) 272-9959
 Fax: 1(800) 737-7018

National Semiconductor Europe
 Fax: (+49) 0-180-530 85 86
 Email: cnjwge@tevm2.nsc.com
 Deutsch Tel: (+49) 0-180-530 85 85
 English Tel: (+49) 0-180-532 78 32
 Français Tel: (+49) 0-180-532 93 58
 Italiano Tel: (+49) 0-180-534 16 80

National Semiconductor Hong Kong Ltd.
 19th Floor, Straight Block,
 Ocean Centre, 5 Canton Rd.
 Tsimshatsui, Kowloon
 Hong Kong
 Tel: (852) 2737-1600
 Fax: (852) 2736-9960

National Semiconductor Japan Ltd.
 Tel: 81-043-299-2309
 Fax: 81-043-299-2408

National does not assume any responsibility for use of any circuitry described, no circuit patent licenses are implied and National reserves the right at any time without notice to change said circuitry and specifications.